

NOTE. ROD-EYE ORIENTATION NOT GUARANTEED

ELECTRICAL OPTIONS/ SPECIFICATIONS	
OUTPUT	SUPPLY (NOM)
'A' 0.5 - 4.5V RATIOMETRIC	5V
'B' ±5V	±15V
'C' 0.5 - 9.5V	24V
'D' ±10V	±15V
'G' 0.5 - 4.5V	24V
SUPPLY CURRENT 12MA TYP. 20MA MAX.	
'E' 4 TO 20MA 2-WIRE	24V (18V MIN.)
'F' 4 TO 20MA SINK†	24V
'H' 4 TO 20MA SOURCE‡	24V
† OUTPUT COMPLIANCE 5-28V	
‡ DRIVE 300Ω MAXIMUM TO 0V	

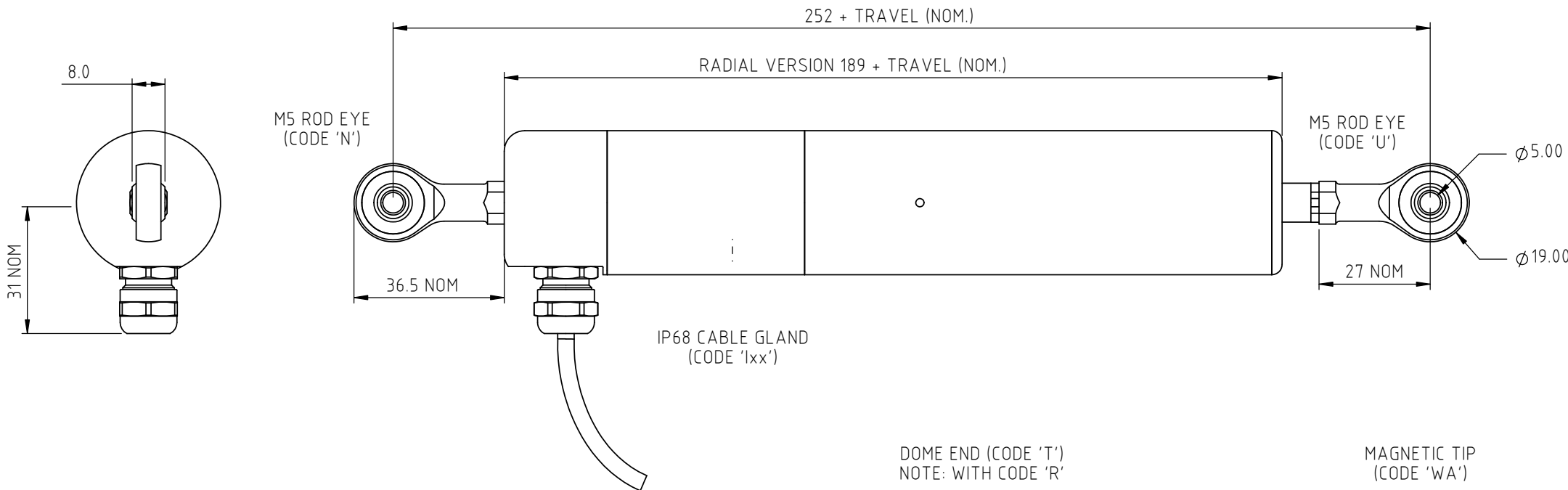
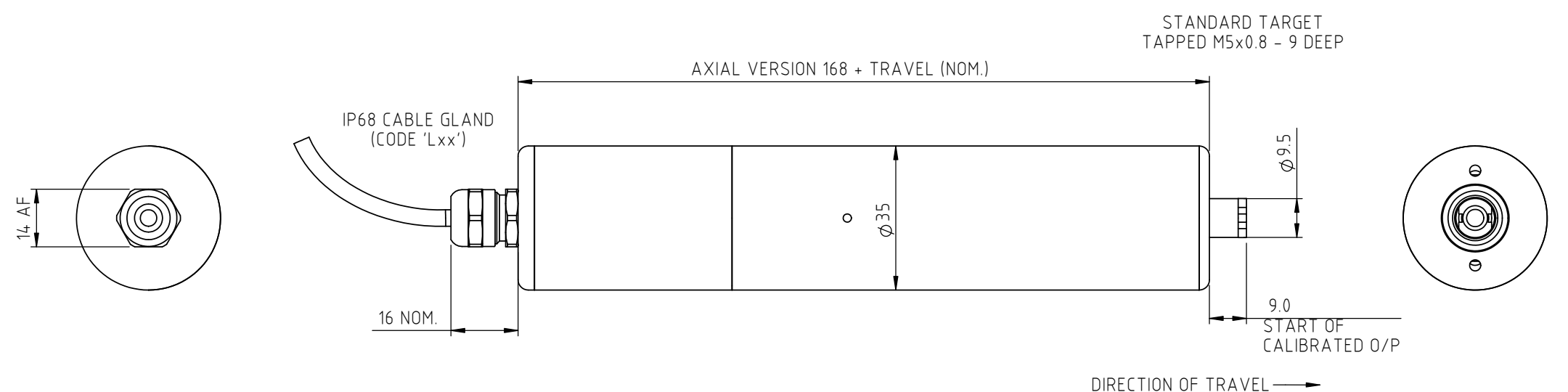

CONNECTIONS:	CABLE	
+VE	3-CORE RED	4-CORE RED
0V	BLACK	GREEN
-VE	-	YELLOW
OUTPUT	WHITE	BLUE
BODY	SCREEN	SCREEN

CABLE: 0.2mm², O/A SCREEN, PUR JACKET. O/D; 3-CORE: Ø4mm, 4-CORE: Ø4.6mm, SUPPLIED WITH 50cm OR REQUIRED LENGTH IN cm. e.g. 'L50' CONNECTORS; MAXIMUM CONDUCTOR CROSS SECTION 0.75mm²

RANGE OF DISPLACEMENT FROM 0-5mm TO 0-800mm e.g.76, IN INCREMENTS OF 1mm
BODY MATERIAL:- STAINLESS STEEL 316.

FURTHER OPTIONS:
 SINGLE PAIR OF BODY CLAMPS 'P'
 TWO PAIRS OF BODY CLAMPS 'P2'
 SPRING RETURN PUSH-ROD, TRAVEL ≤300mm
 RETURN TO EXTENDED POSITION (CODE 'R')
 RETURN TO RETRACTED POSITION (CODE 'S')
 PUSH-ROD FREE (CODE 'V') - NOT AVAILABLE WITH SPRUNG OPTIONS.

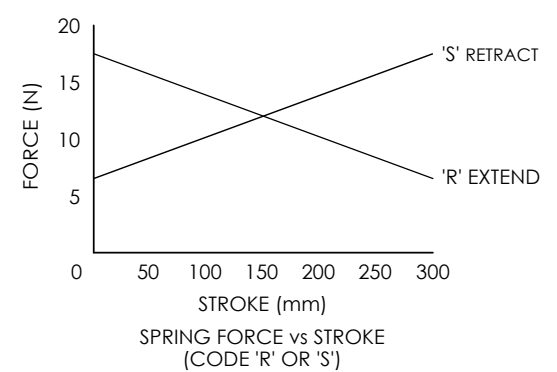

MAXIMUM WORKING DEPTH: 100m (328 ft).
 WHERE THE FREE END OF THE CABLE IS TO BE TERMINATED IN A SUBMERGED POSITION, ADEQUATE SEALING MUST BE PROVIDED TO PROTECT CONNECTIONS.

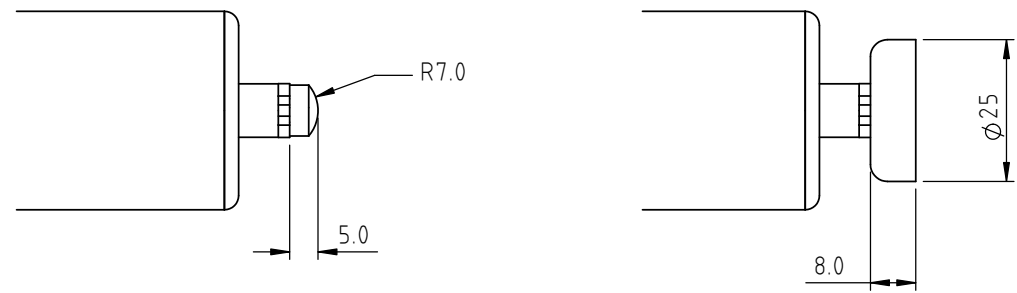

DRAWINGS NOT TO BE CHANGED WITHOUT REFERENCE TO THE CHANGE PROCEDURE.
 CHANGES TO PARTS USED IN INTRINSICALLY SAFE PRODUCT MUST BE APPROVED BY THE AUTHORISED PERSON.
 THIS IS AN UNCONTROLLED PRINT AND WILL NOT BE UPDATED.

REV	CHANGE HISTORY	DR'WN	DATE	CHK'D
F	RAN1311 - MAGNETIC TIP OPTION 'WA' ADDED	ASC	01/06/2023	ASC

THE PUSH-ROD RETRACTS 4mm NOM. BACK FROM THE START OF CALIBRATED TRAVEL.
 THE PUSH-ROD EXTENDS 8mm NOM. BEYOND THE END OF CALIBRATED TRAVEL.
 SPRUNG OPTIONS:- CODE 'R': 1mm, CODE 'S': 2mm.
 CODE 'V': PUSH-ROD NOT RETAINED.



APPROVED BY RDM	REV F		X ±0.4 X.X ±0.2 X.XX ±0.1 DIMS mm
DESCRIPTION S114 SUBMERSIBLE STAND ALONE LINEAR POSITION SENSOR			SCALE 3:4
DRAWING NUMBER S114-11		SHEET 1 OF 1	



S114 SUBMERSIBLE STAND-ALONE LINEAR POSITION SENSOR

Position feedback for industrial and scientific applications

- **Non-contacting inductive technology to eliminate wear**
- **Travel set to customer's requirement**
- **Compact and self-contained**
- **High durability and reliability**
- **High accuracy and stability**
- **Sealing to IP68 10bar/IP69K**



As a leading designer and manufacturer of linear, rotary, tilt and intrinsically safe position sensors, Positek® has the expertise to supply a sensor to suit is an affordable, durable, high-accuracy position sensor. The S114 is an affordable, durable, high-accuracy position sensor. Derived from the P101, it is designed for applications where the sensor would be completely submerged during normal operation, it retains desirable features such as compact size, good sensor performance yet capable of working at pressure. The S114, like all Positek® sensors, provides a linear output proportional to travel. Each unit is supplied with the output calibrated to the travel required by the customer, any stroke from 0-5mm to 0-800mm and with full EMC protection built in. The sensor is very robust, the body and push rod being made of stainless steel for long service life and environmental resistance. Overall performance, repeatability and stability are outstanding over a wide temperature range. The sensor is easy to install with mounting options including M5 stainless steel rod eye bearings and body clamps. The push rod can be supplied free or captive with female M5 thread, an M5 rod eye, dome end or magnetic tip. 1/4" rod eye option available. Captive push rods can be sprung loaded, in either direction, on sensors up to 300mm of travel. The S114 also offers a selection of mechanical and electrical options, environmental sealing is to IP68 10bar/IP69K.

SPECIFICATION

Dimensions	
Body diameter	35 mm
Body length (Axial version)	calibrated travel + 168 mm
Body length (Radial version)	calibrated travel + 189 mm
Push rod extension	calibrated travel + 9 mm, OD 9.5 mm
<i>For full mechanical details see drawing S114-11</i>	
Independent Linearity	$\leq \pm 0.25\%$ FSO @ 20°C - up to 450 mm $\leq \pm 0.5\%$ FSO @ 20°C - over 450 mm
Temperature Coefficients	$< \pm 0.01\%/^{\circ}\text{C}$ Gain & $< \pm 0.01\%$ FS/ $^{\circ}\text{C}$ Offset
Frequency Response	> 10 kHz (-3dB) > 300 Hz (-3dB) 2 wire 4 to 20 mA
Resolution	Infinite
Noise	$< 0.02\%$ FSO
Environmental Temperature Limits (Non Icing)	
Operating	-40°C to +125°C standard -20°C to +85°C buffered -40°C to +125°C
Storage	-40°C to +125°C
Sealing	IP68 10bar/IP69K
EMC Performance	EN 61000-6-2, EN 61000-6-3
Vibration	IEC 68-2-6: 10 g IEC 68-2-29: 40 g
Shock	350,000 hrs 40°C Gf
MTBF	
Drawing List	
S114-11	Sensor Outline
<i>3D models, step or .igs format, available on request.</i>	

Do you need a position sensor made to order to suit a particular installation requirement or specification? We'll be happy to modify any of our designs to suit your needs - please contact us with your requirements.

For further information please contact:

www.positek.com sales@positek.com

Tel: +44(0)1242 820027 fax: +44(0)1242 820615

Positek, Andoversford Industrial Estate, Cheltenham GL54 4LB. U.K.

S114-17h

1 of 2



S114 SUBMERSIBLE STAND-ALONE LINEAR POSITION SENSOR

Position feedback for industrial and scientific applications

How Positek's technology eliminates wear for longer life

Positek's Inductive technology is a major advance in displacement sensor design. Our displacement transducers have the simplicity of a potentiometer with the life of an LVDT/RVDT. Our technology combines the best in fundamental inductive principles with advanced micro-electronic integrated circuit technology. A Positek sensor, based on simple inductive coils using Positek's ASIC control technology, directly measures absolute position giving a DC analogue output signal. Because there is no contact between moving electrical components, reliability is high and wear is eliminated for an exceptionally long life. It also overcomes the drawbacks of LVDT technology – bulky coils, poor length-to-stroke ratio and the need for special magnetic materials, no requirement for separate signal conditioning. We also offer a range of ATEX-qualified intrinsically-safe sensors.

S114	a	b	c	d	e	f	g	h	j
	Displacement	Output	Connections	Option	Option	Option	Option	Option	Z-code

<p>a Displacement Value</p> <p>Factory set to any length from 0-5 mm to 0-800 mm (e.g. 0-254 mm) 254</p> <p>b Output</p> <table border="1"> <thead> <tr> <th>Supply V_{dc} (tolerance)</th> <th>Output</th> <th>Code</th> </tr> </thead> <tbody> <tr> <td>+5V (4.5 - 5.5V)</td> <td>0.5 - 4.5V (ratiometric with supply)</td> <td>A</td> </tr> <tr> <td>±15V nom. (±9 - 28V)</td> <td>±5V</td> <td>B</td> </tr> <tr> <td>+24V nom. (13 - 28V)</td> <td>0.5 - 9.5V</td> <td>C</td> </tr> <tr> <td>±15V nom. (±13.5 - 28V)</td> <td>±10V</td> <td>D</td> </tr> <tr> <td>+24V nom. (18 - 28V)</td> <td>4 - 20mA 2 wire</td> <td>E</td> </tr> <tr> <td>+24V nom. (13 - 28V)</td> <td>4 - 20mA 3 wire Sink</td> <td>F</td> </tr> <tr> <td>+24V nom. (9 - 28V)</td> <td>0.5 - 4.5V</td> <td>G</td> </tr> <tr> <td>+24V nom. (13 - 28V)</td> <td>4 - 20mA 3 wire Source</td> <td>H</td> </tr> </tbody> </table> <p>Supply Current: 'A' 10mA nominal, 12mA max. 'B', 'D' & 'G' 12mA nominal, 15mA max. 'E' 26mA max. 'F' & 'H' 32mA nominal, 35mA max.</p> <p>c Connections Code</p> <p>Cable gland radial IP68 10bar/IP69K Pg7 Ixx</p> <p>Cable gland axial IP68 10bar/IP69K Pg7 Lxx</p> <p>Specify required cable length 'xx' in cm. e.g. L2000 specifies axial cable gland with 20 m of cable, 50 cm supplied as standard. 'Nb': restricted cable pull strength.</p> <p>d Body Fittings Code</p> <p>None default blank</p> <p>M5 Rod-eye bearing radial version only N</p> <p>e Body Clamps Code</p> <p>Body Clamps 1 pair P</p> <p>Body Clamps 2 pairs P2</p>	Supply V_{dc} (tolerance)	Output	Code	+5V (4.5 - 5.5V)	0.5 - 4.5V (ratiometric with supply)	A	±15V nom. (±9 - 28V)	±5V	B	+24V nom. (13 - 28V)	0.5 - 9.5V	C	±15V nom. (±13.5 - 28V)	±10V	D	+24V nom. (18 - 28V)	4 - 20mA 2 wire	E	+24V nom. (13 - 28V)	4 - 20mA 3 wire Sink	F	+24V nom. (9 - 28V)	0.5 - 4.5V	G	+24V nom. (13 - 28V)	4 - 20mA 3 wire Source	H	<p>f Sprung Push Rod Code</p> <p>Not sprung default blank</p> <p>Spring extend R</p> <p>Spring retract S</p> <p>300 mm maximum displacement and captive push rod only.</p> <p>g Push Rod Fittings Code</p> <p>Female thread M5x0.8x9 deep default blank</p> <p>Dome end with spring extend option 'R' T</p> <p>M5 Rod-eye Bearing U</p> <p>Magnetic Tip WA</p> <p>h Push Rod Code</p> <p>Captive push rod retained default blank</p> <p>Non-captive push rod can depart body V</p> <p>j Z-code (optional) Code</p> <p>Tighter Independent Linearity; $\leq \pm xx\%$ FSO @20°C</p> <p>$\leq \pm 0.1\%$ 0 - 10 mm min. to 0 - 450 mm Z650</p> <p>$\leq \pm 0.25\%$ 0 - 451 mm to 0 - 600 mm</p> <p>$\leq \pm 0.5\%$ 0 - 601 mm to 0 - 800 mm max.</p> <p>1/4" Rod eyes with options 'N' and/or 'U' Z827</p>
Supply V_{dc} (tolerance)	Output	Code																										
+5V (4.5 - 5.5V)	0.5 - 4.5V (ratiometric with supply)	A																										
±15V nom. (±9 - 28V)	±5V	B																										
+24V nom. (13 - 28V)	0.5 - 9.5V	C																										
±15V nom. (±13.5 - 28V)	±10V	D																										
+24V nom. (18 - 28V)	4 - 20mA 2 wire	E																										
+24V nom. (13 - 28V)	4 - 20mA 3 wire Sink	F																										
+24V nom. (9 - 28V)	0.5 - 4.5V	G																										
+24V nom. (13 - 28V)	4 - 20mA 3 wire Source	H																										

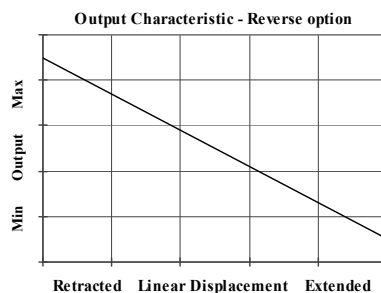
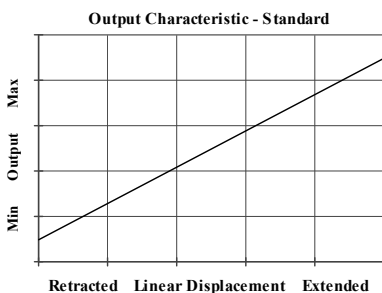

For further information please contact:

www.positek.com sales@positek.com

Tel: +44(0)1242 820027 fax: +44(0)1242 820615

Positek, Andoversford Industrial Estate, Cheltenham GL54 4LB. U.K.

S114-17h

2 of 2



Installation Information

S114 SUBMERSIBLE STAND-ALONE LINEAR POSITION SENSOR

Output Option	Output Description:	Supply Voltage: V_s (tolerance)	Load resistance: (include leads for 4 to 20mA O/Ps)
A	0.5 - 4.5V (ratiometric with supply)	+5V (4.5 - 5.5V)	$\geq 5k\Omega$
B	$\pm 5V$	$\pm 15V$ nom. ($\pm 9 - 28V$)	$\geq 5k\Omega$
C	0.5 - 9.5V	+24V nom. (13 - 28V)	$\geq 5k\Omega$
D	$\pm 10V$	$\pm 15V$ nom. ($\pm 13.5 - 28V$)	$\geq 5k\Omega$
E	4 - 20mA 2 wire Current Loop	+24V nom. (18 - 28V)	$\approx 0 - 300\Omega$ max. @24V ~ 1.2 to 6V across 300 Ω $\{R_L \text{ max.} = (V_s - 18) / 20^{-3}\}$
F	4 - 20mA 3 wire Sink	+24V nom. (13 - 28V)	$\approx 0 - 950\Omega$ max. @24V ~ 3.8 to 19V across 950 Ω $\{R_L \text{ max.} = (V_s - 5) / 20^{-3}\}$
G	0.5 - 4.5V	+24V nom. (9 - 28V)	$\geq 5k\Omega$
H	4 - 20mA 3 wire Source	+24V nom. (13 - 28V)	$\approx 0 - 300\Omega$ max. ~ 1.2 to 6V across 300 Ω

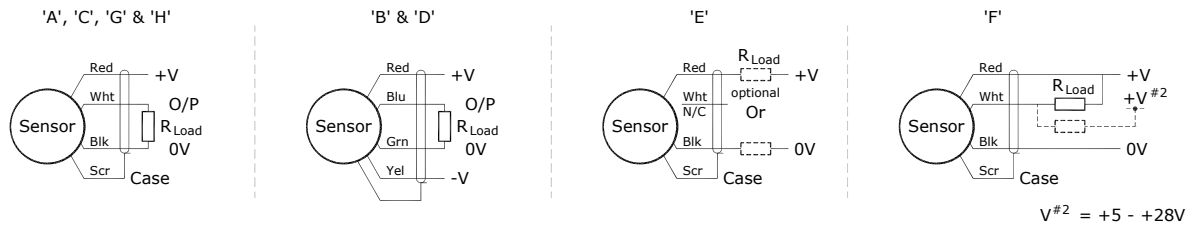

Mechanical Mounting: Depending on options; Body can be mounted by rod eye or by clamping the sensor body - body clamps are available, if not already ordered. Target by M5x0.8 female thread, rod eye or magnetic tip. It is assumed that the sensor and target mounting points share a common earth.

Where the free end of the cable is to be terminated in a submerged position, adequate sealing must be provided to protect connections.

Output Characteristic: Target is extended 9 mm from end of body at start of normal travel. The output increases as the target extends from the sensor body, the calibrated stroke is between 5 and 800 mm.

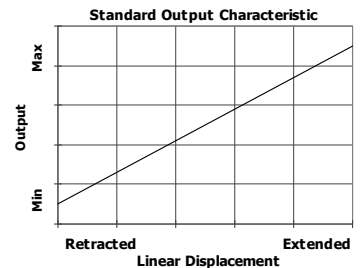

Incorrect Connection Protection levels:-

- A **Not protected** – the sensor is **not** protected against either reverse polarity or over-voltage. The risk of damage should be minimal where the supply current is limited to less than 50mA.
- B & D Supply leads diode protected. Output must not be taken outside $\pm 12V$.
- C & G Supply leads diode protected. Output must not be taken outside 0 to 12V.
- E, F & H Protected against any misconnection within the rated voltage.